

# Photovoltaics for Professionals

For the building industry, the installation of photovoltaic systems has become a new field of activity. Interest in solar energy is growing and future business prospects are excellent.

**Photovoltaics for Professionals** describes the practicalities of marketing, designing and installing photovoltaic systems, both grid-tied and stand-alone. It has been written for electricians, technicians, builders, architects and building engineers who want to get involved in this expanding industry. It answers all the beginner' questions as well as serving as a textbook and work of reference, provides designers and installers with the practical specialist knowledge needed to design and install high quality solar electric systems and gives a comprehensive overview of the major photovoltaic market sectors.

**Photovoltaics for Professionals** covers:

- Marketing and promoting photovoltaics
- Solar cells, PV modules and the solar resource
- Grid-tied PV systems
- Stand-alone PV systems

Practical step-by-step examples are described of how to go about installing systems right from the first customer contact and many useful tips are given to help avoid mistakes.

Over 100 full colour illustrations, 216 pages

Published May 2006

Price: £40.50

Translated and adapted from the German for the international English-language market by Frank Jackson of Green Dragon Energy

Available from <http://www.greendragonenergy.co.uk/pv.htm>

For further details contact [info@greendragonenergy.co.uk](mailto:info@greendragonenergy.co.uk)

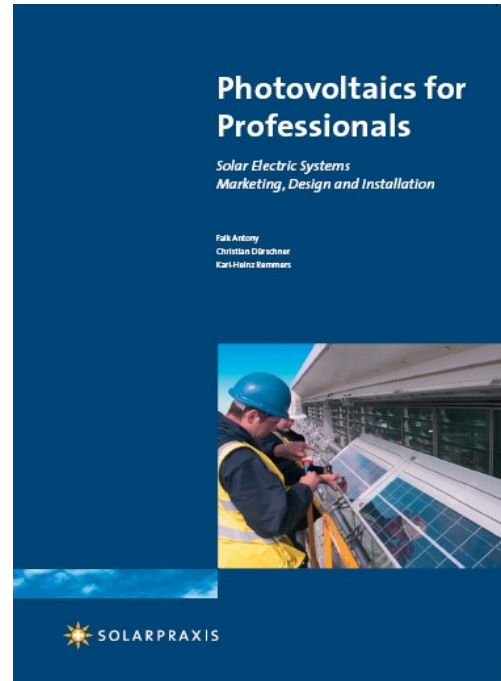

## MARKETING

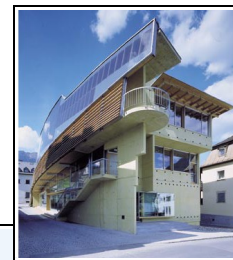

## SYSTEM DESIGN

## STAND-ALONE

## INSTALLATION

Global PV market (2004)

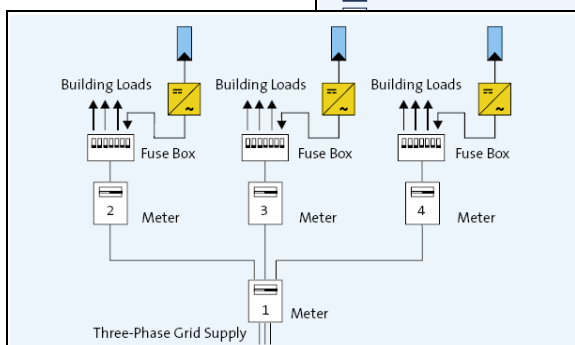
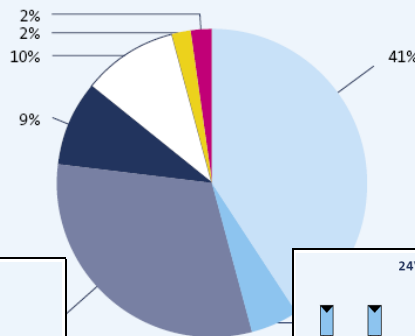

## GRID-TIED

